

UNDERSTANDING & USING CCD CAMERAS

Compact video cameras using CCD (charge-coupled device) sensors are now widely available at low cost, and as a result they find many uses around the home, office and factory. Typical uses including monitoring babies, keeping an eye on kids playing in the yard or swimming pool, viewing callers at the front door and general surveillance of office and factory areas.

In this data sheet we'll explain how CCD cameras work, and give you the information you'll need to select the most appropriate camera (and lens) for any particular job and get the best performance from it.

CCD imagers

At the heart of this type of camera is the *CCD imager*, a specialised type of integrated circuit (IC) which is located just behind the camera's lens. The lens focuses a small image of the scene in front of it directly onto the CCD imager chip, which is behind an optical glass window in its package. The CCD imager then 'scans' the image, and with the help of a few support chips generates a complete standard video signal from it, ready to feed into your TV, video monitor or VCR.

The detailed operation of a CCD imager chip is fairly complex, but here's a simplified explanation of how they work.

Over the active image-sensing area of the chip, there's an array of tiny sensor cells, each typically measuring 10 x 5µm (micrometres) or less. The array of a typical CCD sensor has 297,984 of these cells, arranged in 582 horizontal rows and 512 vertical columns.

Inside each cell there's a light sensitive element — essentially a very tiny photodiode — together with a charge-transfer area which forms part of a long vertical shift register. There are also two control elements, called the readout gate and the overflow gate, and a short section of a long vertical structure called the overflow drain (see Fig.1). All parts of the cell apart from the sensor element are covered by metallisation, so they're 'kept in the dark'.

When light falls on the sensor element (as part of the image), the photons generate charge carriers and as a result a small quantity of charge builds up in that part of the cell. How *much* charge builds up depends on the amount of light reaching the cell, of course. The area directly under the sensor element is designed to contain this charge, as a kind of 'bucket'.

Then after a short time, a voltage pulse is applied to the readout gate. This has the effect of lowering the 'retaining wall' on that side of the bucket, allowing the accumulated charge to flow out of the sensor bucket and into the charge-transfer area.

So after the readout pulse, the charge that was generated in the sensor element by the incident light has been shifted into the charge-transfer area alongside. And as mentioned earlier this area is actually part of a long vertical shift register, which links all of the charge-transfer areas in a complete column of cells. This shift register is used to transport the charges in each of the charge-transfer areas down the columns, and ultimately out of the chip.

How does the shift register work? By passing the charge in each charge-transfer area down to the one below it, using exactly the same kind of process that was used to shift the charges into them from the sensor elements. There's another set of gates between each pair of adjacent transfer areas in the column, and by pulsing these the charges are

transferred from each one to the one below. It's like a traditional 'bucket brigade'.

Along the bottom of all the columns, there's yet another of these 'bucket brigade shift registers' — only this time it's horizontal. So by pulsing the transfer gates linking the bottom row of charge-transfer elements, the charges in them can be shuffled out of the image array, in serial order. Here they're passed through a charge-to-voltage amplifier stage to produce the output video signal. Fig.2 shows the overall charge flow paths in the image sensor array.

Getting back to the basic imager cell of Fig.1 for a moment, you're probably wondering what that overflow gate and drain are for. Basically, they're to prevent the sensor elements from accumulating too much charge, if the light falling on them is too great (i.e., over exposure).

The idea here is that the overflow gate is held at a voltage

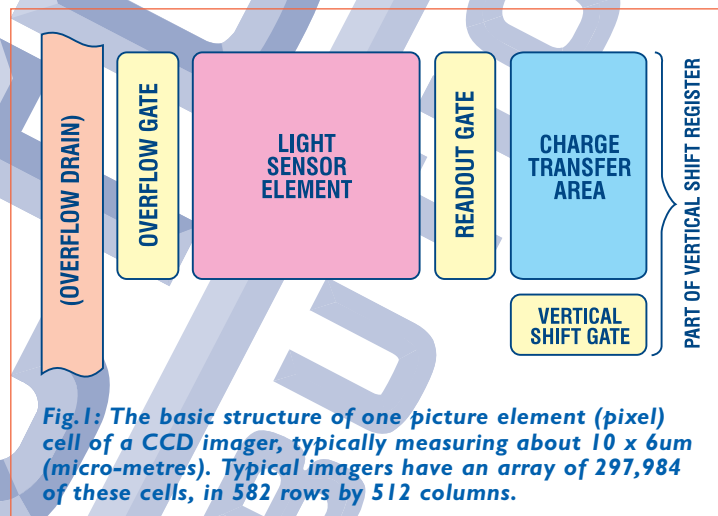

Fig.1: The basic structure of one picture element (pixel) cell of a CCD imager, typically measuring about 10 x 6µm (micro-metres). Typical imagers have an array of 297,984 of these cells, in 582 rows by 512 columns.

level where the 'retaining wall' on *that* side of the sensor 'bucket' is a little lower than on the charge-transfer region side. This means that if the charge builds up in the bucket to reach that level, any further charge simply flows over the 'wall' into the overflow drain, where it's drained away. This system prevents the photosensor elements from ever completely filling with charge — which would tend to make the CCD imager saturate and its output video 'wash out' in highlight areas.

By the way the type of CCD imager we've described here is known as the *interline transfer* type, because of the way the charges from the sensor elements are shifted first sideways into their own charge-transfer region, then down the vertical shift registers and finally out via the horizontal shift register. This is the type of CCD imager used in most home video cameras, camcorders and digital still cameras.

There are other types of CCD imager, which use a different system to shuffle the charges out of the array. The *frame-transfer* system has a second complete storage array underneath the sensor array, which allows charges from the next image to be built up while the first charges are being processed. However these chips are roughly twice as complex as the interline transfer type and also tend to need a mechanical shutter for exposure control, so they're more costly.

Electronic shutter

The basic interline-transfer CCD imager provides a fairly simple way of controlling the exposure for each image: by

varying the length of time that the charge can build up in each sensor element, before it's shifted out into the charge-transfer region. So by adjusting the timing of the readout pulses, the control circuitry effectively controls the exposure time.

This property of CCD imagers is usually described as their *electronic shutter*, and most CCD cameras use it to provide a simple means of allowing the camera to deliver clear video signals over a fairly wide range of lighting levels.

With most CCD imagers, this 'automatic electronic shutter' or **AES** function has an effective range from about 10 μ s (1/100,000th of a second) up to almost 20ms (1/50th of a second) — the video field period. This gives an exposure control range of almost 2000:1.

B&W or colour

The photosensor elements of a CCD imager respond to any light in a fairly wide range of wavelengths. In other words, they can't distinguish between colours. So a basic CCD imager forms what is essentially a B&W (black and white) video camera.

Two different systems are used to produce a CCD **colour** camera. In the *single chip* system used in most low cost video cameras, camcorders and digital still cameras, tiny strips of colour filter material are laid on the top of the CCD imager, covering the sensor columns in a repeating green-red-blue sequence. This restricts each column of sensor elements to responding primarily to the colour passed by that filter, so that the video signal that emerges from the imager has colour information multiplexed into it. All of the video is used by the processing circuitry to generate the luminance signal, but the information corresponding to each trio of sensor bits can also be used to generate the chrominance (colour) signal.

The alternative way of producing a CCD colour camera is to use three separate CCD imagers, each receiving its light via a filter for one of the three primary colours. The three imagers are mounted around an optical prism/splitter system behind the lens, so that all three receive exactly

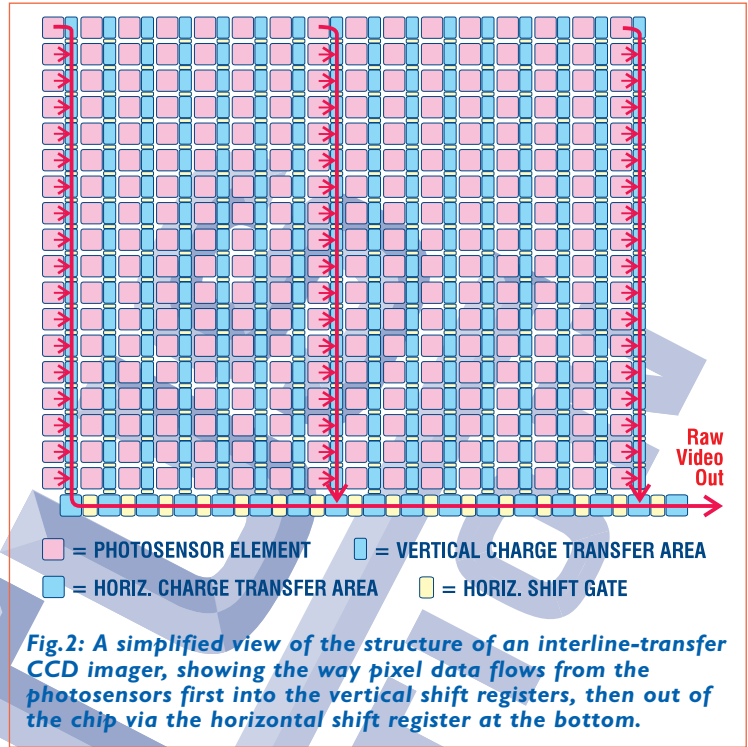

same image. This *three-chip* colour system can deliver higher quality colour signals than the single-chip system, but tends to be much more expensive because of the three imagers and more complex optical system. It's used mainly in broadcasting and professional TV cameras.

Imager size

The majority of domestic and industrial CCD video cameras use one of two main sizes of CCD imager. These are usually called the **1/3"** type and the **1/4"** type, and both are made in either B&W or colour versions. Other sizes are made, including a smaller **1/5"** type and a larger **1/2"** type, but they're much less common.

The active image size of a nominal **1/3"** CCD imager is actually 4.8 x 3.6mm, while that of a nominal **1/4"** imager is 3.6 x 2.7mm. In each case the larger of the two dimensions is image *width*. Note that the ratio of the two is 1.33:1 in each case. This is known as the **aspect ratio**, and matches that of a standard CCIR/PAL TV signal (usually expressed as 4:3).

Resolution

Broadly speaking, the image clarity or 'picture sharpness' delivered by a CCD camera depends on its **resolution** — how well it reproduces or 'resolves' fine details in the image. However there are a number of ways of describing the resolution, which can make things a bit confusing.

For example there's the basic resolution of the camera's CCD imager: how many rows and columns of sensor elements it uses, which determines the number of picture elements or *pixels* that it uses to analyse the image.

Most low cost CCD video cameras use an imager with a basic resolution of either 512 or 500 columns across the picture, and 582 rows down the picture. This gives roughly one row of sensor pixels for each active line of a nominal 625-line video image, and the potential of 500 or more

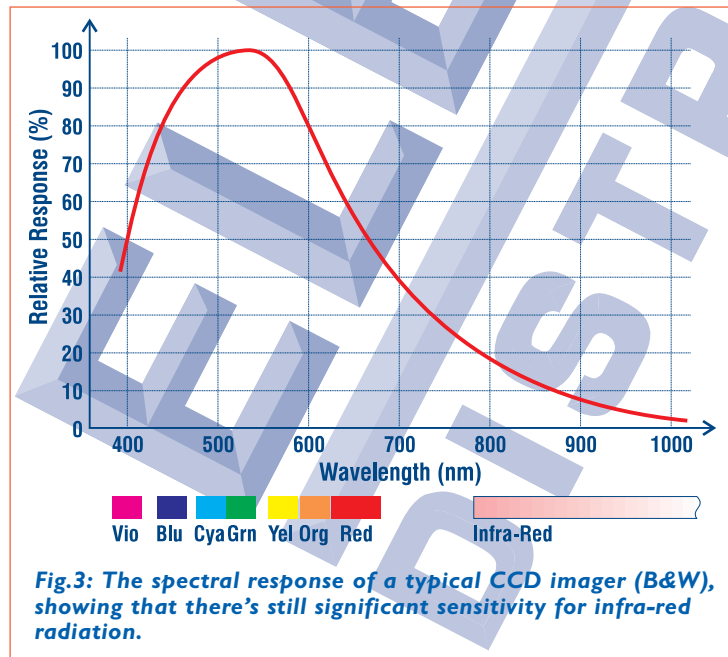

pixels along each line.

But the final horizontal resolution of the image isn't determined only by the CCD imager. It's also influenced by the frequency response of the other chips used to process the video signal from the imager, and these inevitably reduce the effective resolution to some extent.

To give you a better idea of the final image resolution from a camera, manufacturers usually also specify an effective horizontal resolution figure as well as the imager's raw pixel figures. This resolution figure is usually quoted in terms of the number of alternating black and white lines that can be resolved across the width of the image — i.e., along each line. This figure usually turns out to be rather lower than the potential 500- or 512-line resolution you'd expect from the imager: typical cameras provide figures ranging from 330 to 420 lines. However a figure of 400 lines or more will generally give images that most people find quite clear and 'sharp'.

Note, though, that the final clarity of the images produced by any camera will also depend on the performance of the video monitor or TV receiver it's displayed on. If the monitor has relatively poor video response, the image from the best camera will still look 'soft' or 'furry'.

Spectral response

The sensor elements of a basic CCD imager (B&W) respond to wavelengths covering the complete range of visible light, and beyond (see Fig.3). The peak response is usually between about 500 and 550nm (nanometres), corresponding to green-yellow light. However the sensors often still have 20% or more of their peak sensitivity at 780nm, which is the start of the *infra-red* (IR) part of the spectrum and outside the range visible to the human eye.

This wide spectral sensitivity of CCD imagers has both advantages and disadvantages. On the plus side, it means that CCD cameras can be used with IR illumination to monitor areas that seem to the human eye to be in total darkness. This makes them very suitable for surveillance.

On the other hand, the fact that a CCD imager responds to IR as well as visible light can degrade image quality when a camera is viewing a scene where there's significant IR radiation as well as visible light. This is because many lenses have a different focal length at different wavelengths — so a focus setting that's correct for visible light tends to result in a defocused (blurry) IR image, and vice-versa.

So with many CDD cameras, the only way to get a really

sharp and clear image of some scenes is to use an **IR-rejection filter** to block out the IR components in the image. This tends to be more of a problem with B&W CCD cameras than with colour cameras, as the colour filter stripes tend to reduce the imager sensitivity to IR wavelengths. However some colour cameras still have a significant sensitivity to IR, especially if they've been designed to be sensitive down to very low light levels.

CCD cameras

Currently there are two broad types of low cost video camera based on CCD imagers: the 'naked board' type, usually with a built-in lens, and the fully encased type. The latter can have either a built-in lens or be designed to accept replaceable screw-in lenses. Both types are available in either B&W or colour, and the fully encased type often consists of a board-type camera in a sturdy but compact metal case, fitted with a lens mount at the front and power/output connectors at the rear.

Whether of the naked-board or encased type, most of the latest CCD cameras are fully automatic in operation and have virtually no manual controls or adjustments apart from focusing via the lens mounting. Exposure control is automatic and based on the CCD imager's AES function. This typically copes with a 2000:1 range in light level, and allows the use of low cost fixed-aperture lenses. If a camera needs to operate at a very high light level, a neutral-density filter can often be used to prevent overload.

When a CCD camera *does* need to be used where lighting levels vary over a range of much wider than 2000:1, an **auto iris** lens can be used to allow it to cope with the larger range. These lenses are not cheap (often costing as much or more than the camera itself), but they give somewhat better performance than the AES system. When such a lens is fitted the camera's own AES function is often disabled.

Nowadays both the naked-board and fully enclosed types of camera are often equipped with an electret microphone insert and preamplifier, so they deliver an audio signal as well as the video from the CCD imager.

Some enclosed cameras are also provided with a number of forward-facing IR emitting LEDs, to give the camera built-in IR scene illumination. This makes them especially suitable for covert surveillance work.

Of course IR illuminators (usually just an array of IR LEDs) are available at quite low cost anyway, so it's also possible to use these with cameras that don't have the inbuilt illumination, to achieve the same result.

Power supply

Most small CCD cameras are designed to be powered from a fairly well regulated source of 12V DC (typically +/-10%). This makes them very suitable for operation from a battery supply, for example, but they can malfunction or even be damaged if the voltage rises much above 13.5V. That's why it is unwise to attempt running them from low cost unregulated '12V plug pack' mains adaptors, as the output from these can easily rise to 16-17V or more.

A small number of cameras do have internal regulation circuitry and are able to cope with a wider range of input voltages — say 9-15V. However in general, when operating any CCD video camera from mains power it's safest to use an electronically *regulated* 12V power adaptor or power supply.

Lenses

Naked-board and very compact enclosed CCD cameras usually come complete with an integral lens and holder,

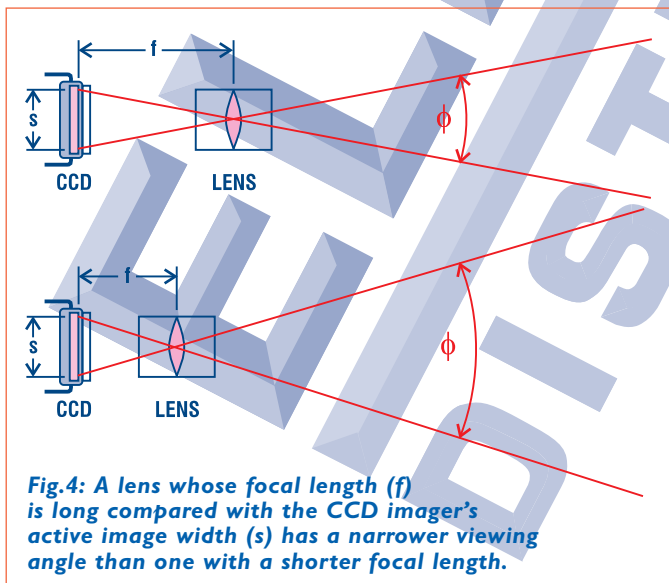

Fig.4: A lens whose focal length (f) is long compared with the CCD imager's active image width (s) has a narrower viewing angle than one with a shorter focal length.

fitted directly over the CCD imager on the front of the board. These lenses are generally one of two main types: the fixed-focus 'pinhole' type or the adjustable focus three-element type.

The 'pinhole' type lens isn't a true pinhole, but a low cost single-element lens with a short focal length and a small fixed aperture (often 2-3mm), so that it provides a depth of field extending from about 2m to infinity. However the single lens element limits image quality, and the small aperture restricts such cameras to fairly high lighting levels.

Better image quality is generally available from the type of camera using a three-element lens, not only because of the additional elements but also because of the adjustable focus. The aperture is usually somewhat greater too, making the camera more useful at lower lighting levels.

Although the built-in lenses fitted to naked-board and compact cameras can deliver quite good image quality, much greater flexibility is available from the larger enclosed type of camera, which generally offers the ability to use *interchangeable lenses*. In most cases these lenses are of the screw-in 'CS' type, which is a modified version the 'C mount' originally developed for 16mm movie film cameras. The 'CS' version is made with a shorter length extending behind the mounting thread, to ensure they clear the CCD imager.

Focal length

Whether they're built into the camera or are of the screw-in interchangeable type, the key parameter used to describe camera lenses is their *focal length*. This is basically a measure of the spacing needed between the lens's centre of focus and its focal plane (here, the active surface of the CCD imager), when the lens is producing a properly focussed image of an object at infinity.

The focal length of CCD video camera lenses is usually

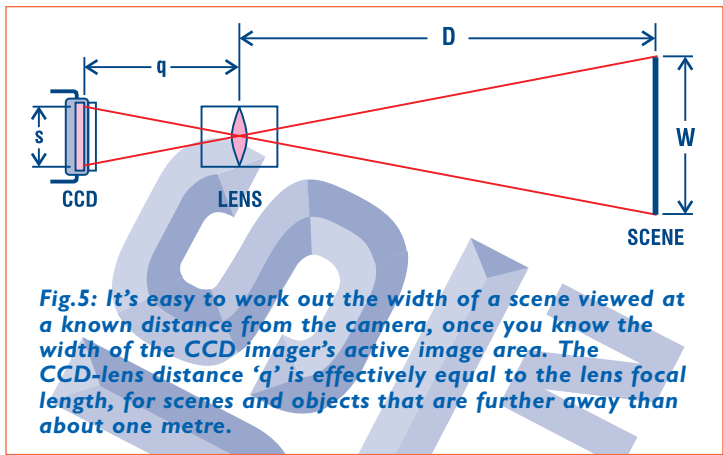

Fig.5: It's easy to work out the width of a scene viewed at a known distance from the camera, once you know the width of the CCD imager's active image area. The CCD-lens distance 'q' is effectively equal to the lens focal length, for scenes and objects that are further away than about one metre.

'wide angle' effect.

The actual viewing angle of a lens when used with a particular CCD imager can be found using this expression:

$$f = 2 \times \tan^{-1}(s/2q)$$

where f is the horizontal angle of view, s is the width of the CCD sensor's active image area and q is the distance between the centre of focus of the lens and the CCD imager plane.

Note that when the lens is focussed at objects further away than about 1m, q will be very close to f , the focal length of the lens. So for most purposes you can simply substitute f for q in this expression, to give:

$$f = 2 \times \tan^{-1}(s/2f)$$

However this *isn't* true if you use the lens to focus on *very close* objects, because q then becomes significantly longer than f . In these cases you need to use the first expression.

Another point to note from these expressions is that a lens with a particular focal length will give a wider angle of view with a CCD imager having a larger active image width, and vice-versa. For example a lens of 4mm focal length will give a 48° angle of view with a camera using a 1/4" CCD imager, but a 62° angle of view with a camera using a 1/3" imager.

Typically the lenses built into CCD cameras have a focal length of about 2.5mm, which tends to give a fairly wide angle of view: around 90° with a 1/3" imager or 70° with a 1/4" imager.

Cameras designed especially for 'front door viewer' use are fitted with a special type of lens with a very wide angle of view — typically 170°, which is almost a hemisphere. This type of lens is often called a 'fish eye'.

TABLE 1: CCD Imagers, Lenses & Scene Widths							
Camera Imager	Lens Focal Length	Horizontal Angle of View	Scene Width @ 1m	Scene Width @ 2m	Scene Width @ 3m	Scene Width @ 5m	Scene Width @ 10m
1/3" (Active Image Area 4.8 x 3.6mm)	(2.32mm)	92°	2.1m	4.2m	6.2m	10.3m	20.7m
	4mm	62°	1.2m	2.4m	3.6m	6m	12m
	6mm	44°	800mm	1.6m	2.4m	4m	8m
	8mm	33°	600mm	1.2m	1.8m	3m	6m
1/4" (Active Image Area 3.6 x 2.7mm)	(2.57mm)	70°	1.4m	2.8m	4.2m	7m	14m
	4mm	48°	900mm	1.8m	2.7m	4.5m	9m
	6mm	33°	600mm	1.2m	1.8m	3m	6m
	8mm	25°	450mm	900mm	1.35m	2.25m	4.5m

given in millimetres (mm), although sometimes the horizontal viewing angle is given instead.

Viewing angle

Because of the way lenses work, the focal length of a lens determines how wide an angle it 'views', when producing an image of a certain width — here, the width of the active image area of the CCD imager it's being used with.

As Fig.4 shows, the viewing angle is narrower when the lens has a focal length (f) that's relatively long compared with the active image width of the sensor (s). Conversely it's wider when the lens has a relatively short focal length. So *longer* focal length lenses tend to give a 'telephoto' or close-up effect, while those with *shorter* focal length give a

Scene width

Although it's handy to be able to visualise the angle of view of a lens when used with a particular camera and its imager, often it's more important to be able to work out the best lens to use in order to cover a particular *scene width*, at a known distance from the camera.

This is also quite easy to work out. As you can hopefully see from Fig.5, The ratio of scene width W to the camera-scene distance D is the same as the ratio between s , the active width of the CCD imager and q the lens-imager distance. In other words,

$$W/D = s/q$$

And as before q will be almost exactly the same as f the

Electus Distribution Reference Data Sheet: CCDCAMS.PDF (5)

focal length of the lens, for objects and scenes more than about 1m distant from the camera.

So if you know the scene width you want, and its distance from the camera, you can find out the focal length of the lens you need by rearranging the above expression into:

$$f = s \times (D/W)$$

If you want to cover a scene 3m wide at a distance of 5m from the camera, for example, this will give a D/W figure of 5/3 or 1.666. Therefore if you have a camera with a 1/3" CCD imager, where $s = 4.8\text{mm}$, you'll need a lens with a focal length of 4.8×1.666 , or 8mm. On the other hand if you want the same scene width using a camera with a 1/4" imager, where $s = 3.6\text{mm}$, you'll need a lens with a focal length of 3.6×1.666 , or 6mm.

To save you having to work these figures out for yourself every time, we've already worked out the viewing angle and scene widths for most of the common combinations of CCD imager and lens focal length. These are shown in Table 1.

Output wiring

Most CCD video cameras deliver standard CCIR/PAL composite video which is suitable for feeding straight into the direct video input of standard TV sets, video monitors and VCRs. The video signal is typically 1V peak-to-peak at 75 ohms impedance, which means that coaxial cables of the same impedance and up to about 20m long can be used to deliver the signal to the TV/monitor without any serious degradation.

Where the camera must be used further away from the monitor, there are two main alternatives to coaxial cable. One is to use video **baluns** (wideband balanced-to-unbalanced transformers) to couple the video signal into Category 5 twisted-pair cabling, as used for computer data networks. This approach allows the use of Cat-5 cabling up to 600m long for B&W video signals, and 300m long for colour signals.

Video baluns are available to handle either the video signal alone, or the video and two audio signals together. In both cases they're passive devices and need no external power.

The other main way of sending the CCD camera signals over a longer distance to the TV/monitor is to use small UHF video/audio transmitter and receiver units — the type of system used to reticulate cable TV video and audio around a home. This approach can give good results at distances of up to 100m or so.

Where the camera signal is being sent only to a TV receiver, a simpler approach is to use a low cost RF modulator unit of the same type used for video games. This allows the camera signal to be tuned in on a suitable vacant channel, and doesn't require the use of a separate receiver or demodulator unit. The useful range can be up to about 30 metres.

CMOS cameras

Although they're nominally standard ICs, CCD imager chips have to be made using different processing steps from those used in most other ICs, to produce their array of charge-containment regions. This makes them relatively expensive, and has also made it difficult for manufacturers to combine them with the necessary auxiliary circuitry to produce a complete 'camera on a chip'.

Because of these shortcomings, IC designers have recently put a lot of effort into designing imager chips using standard CMOS processing technology, with the aim of replacing CCD imagers. To date they've had only limited success, and although CMOS cameras have begun to appear their performance usually doesn't compare all that well with the CCD type. The image resolution is usually quite modest, and they have a relatively high noise level and image 'lag' compared with CCDs.

It's likely that these drawbacks will be overcome in the future, though, and CMOS imagers and cameras will probably replace CCDs eventually. But for the present, CCD imagers and cameras deliver very good performance and value for money.

(Copyright © Electus Distribution, 2001)

CCD CAMERAS, LENSES & ACCESSORIES STOCKED BY ELECTUS

Electus stocks a very wide range of CCD cameras — from naked-board and very compact enclosed types to types built into darkened plastic domes, very compact 'bullet' shaped cameras and a 'door viewer' type with a wide angle fish-eye lens, all the way to pro-style cameras which take standard interchangeable CS lenses. Most styles of camera are available in either B&W (CCIR) or colour (PAL) versions, and many include a built-in microphone and audio preamp. There are models which include built-in IR illumination, and a 'dome' model which has built-in pan and tilt servo motors for remote positioning.

Needless to say Electus also stocks a broad range of accessories for the cameras, including interchangeable lenses — including an auto-iris lens for situations where the camera must cope with a very wide range of lighting levels. There's also an IR illuminator, internal and external mounting brackets, rugged camera housings for external or internal use, replacement and extension cables, Cat-5 video and AV baluns, monitors, camera switchers and video processors, AV transmitter/receiver sets and RF modulators. Everything needed for just about any kind of CCTV system!

For more information please refer to the latest Electus Distribution Catalogue, or visit the website at www.electusdistribution.com.au