

ZD1200 Flow Sensor

Features :

- Small and compact dimension
- Easy connection, 1/2" BSP thread
- High reliability and durability
- Installation flexibility : vertical or horizontal
- Wide rated voltage : 2.4 to 26 VDC
- Hall effect sensor, digital output

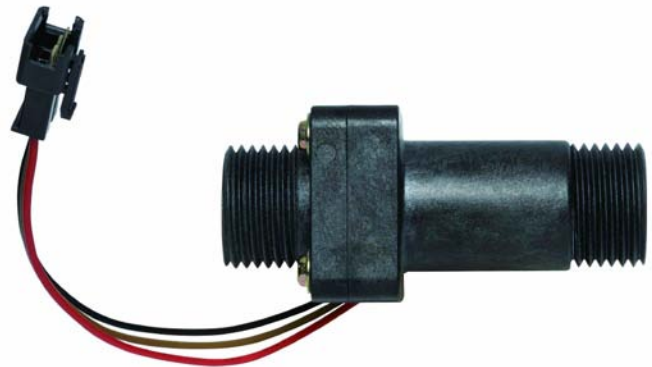

Application :

- ✓ Water heater, boiler and heat pump

1.0 Mechanism :

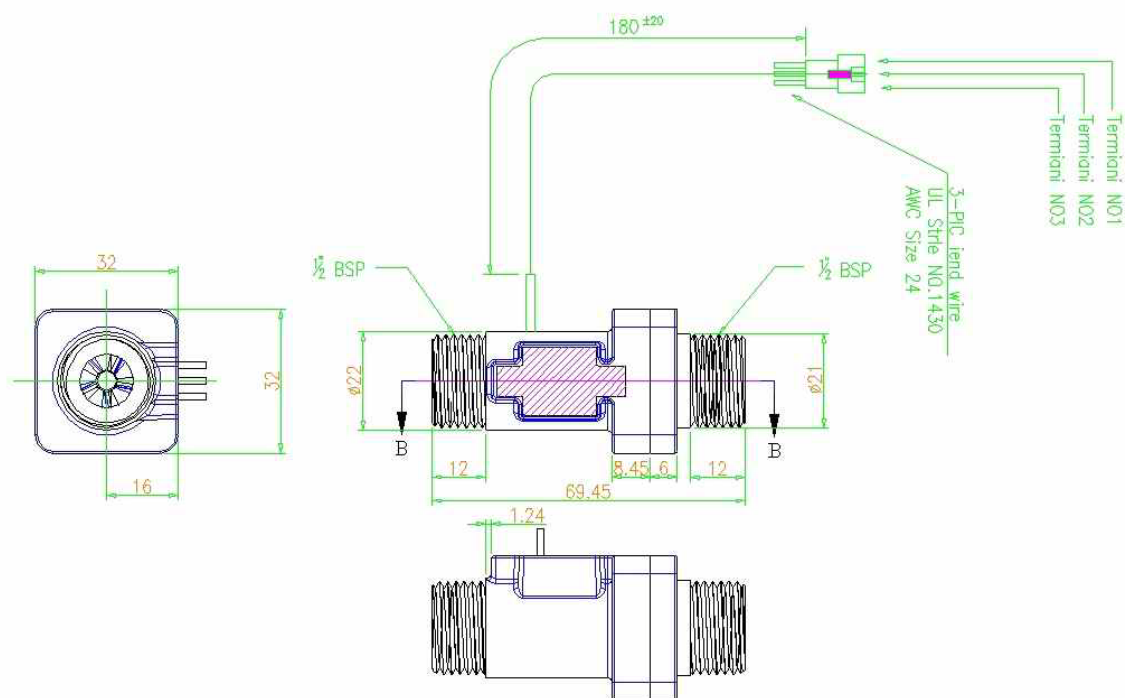

2.0 Electrical :

Supply voltage : 2.4 – 26 V DC

Supply current : typical 3.0 mA, maximum 6.0 mA.

Output mode : open collector

Output rise time : typical 1.0 μ second. maximum 10 μ second.

Output falling time : typical 0. 3 μ second. maximum 1.5 μ second.

Wire connection : Terminal 1 (Red) : Vdd

Terminal 2 (Brown) : Vout

Terminal 3 (Black) : Gnd

3.0 Application :

Mounting Method : Horizontal to Vertical

Range of Flow Rate : 1.5 – 25 L/min.

Calibration(horizontal mounting) : 5.1 \pm 2.0 pps @ 1.5 Liter/min.
 13.5 \pm 2.0 pps @ 3.0 Liter/min
 28.7 \pm 3.0 pps @ 6.0 Liter/min.
 42.1 \pm 4.0 pps @ 9.0 Liter/min.
 71.4 \pm 7.0 pps @ 15.0 Liter/min.
 93.9 \pm 9.0 pps @ 20.0 Liter/min.

Calibration(vertical mounting) : 7.8 \pm 2.0 pps @ 1.5 Liter/min.
 15.9 \pm 2.0 pps @ 3.0 Liter/min
 29.8 \pm 3.0 pps @ 6.0 Liter/min.
 42.0 \pm 4.0 pps @ 9.0 Liter/min.
 70.4 \pm 7.0 pps @ 15.0 Liter/min.
 93.5 \pm 9.0 pps @ 20.0 Liter/min

Maximum working pressure : 1MPa

Fluid : Cold / Warm Water

Fluid temperature : 0 ~ 80 $^{\circ}$ C

Environment temperature : -20 ~ 80 $^{\circ}$ C

Body Materials : PPS with 30% glass fiber